

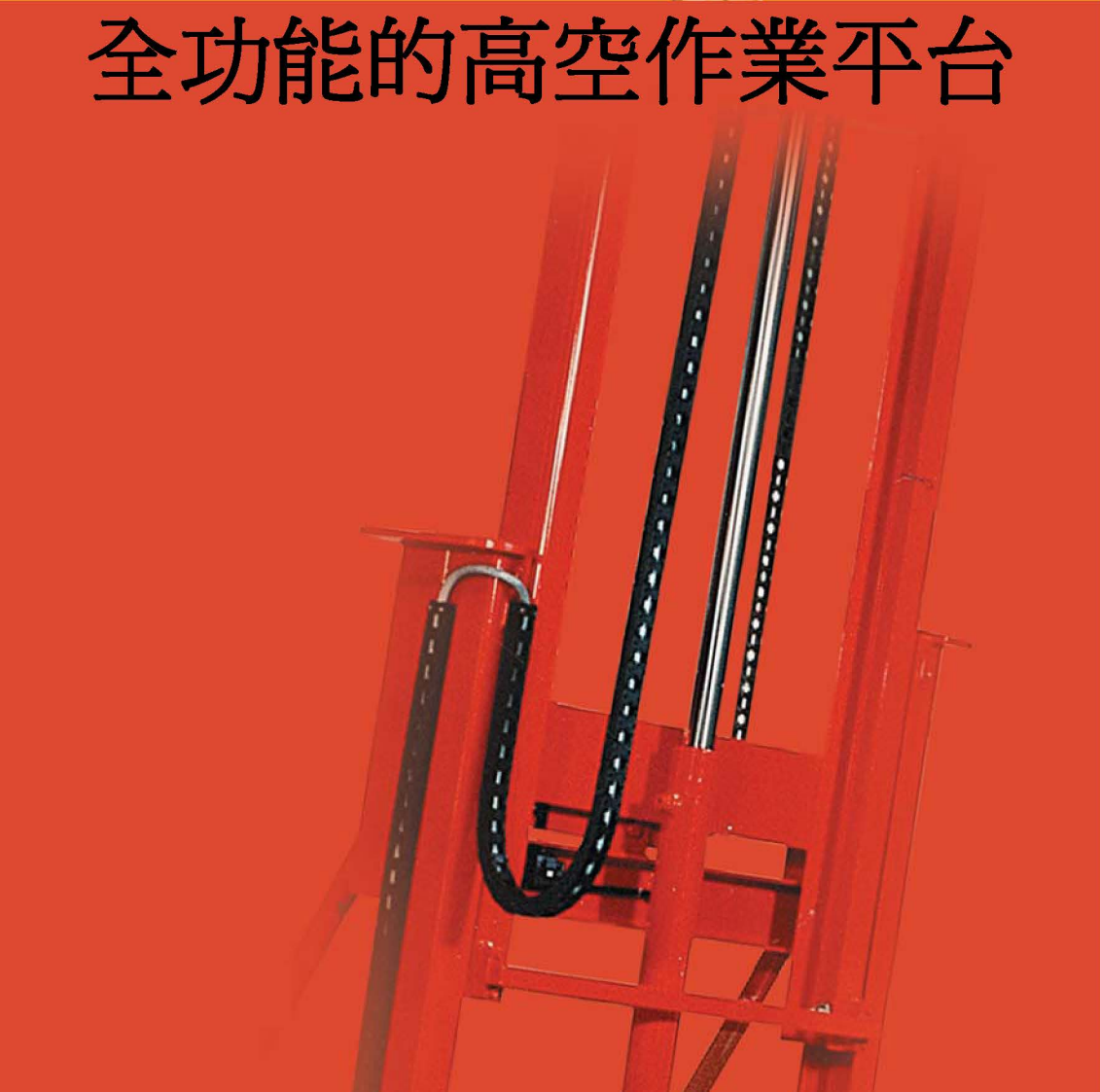

ALL PURPOSE PLATFORMS

# 全功能的高空作業平台



# All Purpose Platform Type KA 6 - KA 14

## 全功能作業平台

## 型號KA6- KA 14

castor range 活動輪範圍

Favourable overall dimensions allow easy manoeuvring through narrow doors and twisty passages. Compact design and close wall approach permit universal usage. Easy one-person operation, a few moves next to no time make the platform ready for instant use: simple setting of stabilisers, pulling up the hand railing and connecting to current supply.

有利的整體尺寸允許容易地操縱通過狹窄的門和扭曲的通道。緊湊的設計和可接近牆面允許普遍使用。一個人可輕鬆的操作，只要幾個動作，不用時間做平台準備即可使用：穩定器的簡單設置，拉起手扶欄杆並連接到當前的電源。

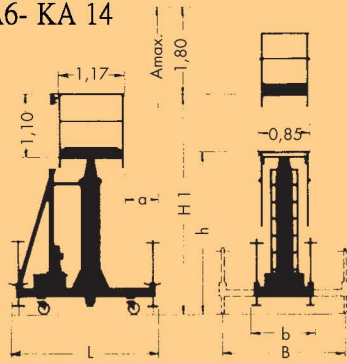

Type	KA 6	KA 8	KA 9	KA 10	KA 12	KA 14
Capacity	kg 300 kg = 2 persons + 140 kg material					
A max.	m 6.5	m 7.8	m 9.0	m 10.1	m 11.9	m 13.6
H1	m 4.7	m 6.0	m 7.2	m 8.3	m 10.1	m 11.8
h	m 1.96	m 1.96	m 1.96	m 1.96	m 2.59	m 2.59
b	m 0.93	m 0.93	m 0.93	m 0.93	m 1.10	m 1.10
L	m 1.98	m 1.98	m 1.98	m 1.98	m 2.26	m 2.26
B	m 1.82	m 1.82	m 1.82	m 1.82	m 1.99	m 1.99
a	m 0.34	m 0.34	m 0.34	m 0.34	m 0.42	m 0.42
Dead weight	kg 620	kg 650	kg 690	kg 735	kg 895	kg 990
Supply voltage	400 V or 230 V					
	Special equipment on request					



They allow safe overhead access in workshops or outside installations, even in areas of difficult reach. They conform with all safety requirements as per German UVV-Cranes BGV D6 § 10 specifying the use of stable and safe working platforms. 即使在難以到達的地區，它們也允許在工作間或室外安裝中安全架空進入。它們符合所有安全要求，根據德國UVV-起重機BGV D6§10規定使用穩定安全的工作平台。

The high stability matches the requirement as per EN 280 allowing safe working up to wind forces gale 6.

Based on these high safety requirements the platforms offer universal application for all assembling, maintenance, repair and cleaning work. 高穩定性符合EN 280的要求，允許安全作業達到6級風力。基於這些高安全性要求，平台對於所有組裝，維護，維修和清潔工作提供通用應用。

45 years of experience and most modern technical know-how result in the approved design of electro-hydraulic All Purpose Platforms.

45年的經驗和最先進的技術訣竅，導致電油壓全功能作業平台的認可設計。

# All Purpose Platform Type KF 6 - KF 14

trailer mounted range, model "Vario"  
全功能作業平台KF6- KF 14型

拖車安裝範圍, 型號 "Vario"  
for easy transportation over long distances,  
with hitch for cars or pick-ups, with coup-  
pling for trucks.

If required, the trailer can be detached,  
the compact platform can be used  
in narrow spaces too.

方便長途運輸附有卡車連軸器用以  
鉤住車子或貨車, 如果需要, 拖車  
可以脫離作業平台, 而在狹窄的空間  
中使用。

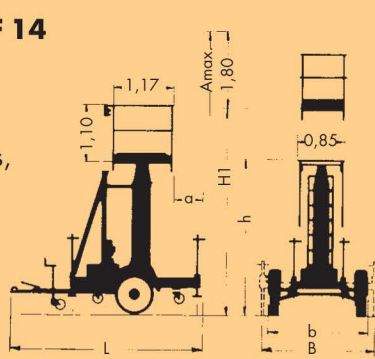

with detachable  
trailer

Type	KF 6	KF 8	KF 9	KF 10	KF 12	KF 14
Capacity	kg	300 kg = 2 persons + 140 kg material				
A max.	m	6.7	8.0	9.2	10.3	13.9
H1	m	4.9	6.2	7.4	8.5	10.4
h	m	2.04	2.04	2.04	2.04	2.70
b	m	1.60	1.60	1.60	1.60	1.85
L	m	2.98	2.98	2.98	2.98	3.40
B	m	1.82	1.82	1.82	1.82	1.99
a	m	0.34	0.34	0.34	0.34	0.42
Dead weight	kg	725	755	800	850	1100
Supply voltage		400 V or 230 V				
		Special equipment on request				



The honed and ground telescopic mast  
has an anti-pivoting device in form of  
key and keyway inside the tubes.

磨孔和研磨加工伸縮式桅杆在管內  
具有鍵和鍵槽形成的防旋轉裝置。

The retracted tube sections are entirely  
surrounded by hydraulic fluid so pro-  
tected against corrosion. Additionally  
a long lifetime is given by hardchrome-  
plating of the tubes as a standard feature.

縮回的管節被液壓流體完全包圍,  
以防止腐蝕。另外長壽命是由硬鉻  
電鍍作為管節的標準特性。



All control elements inclusive the manu-  
ally operated emergency lowering valve  
are integrated into the hydraulic mono-  
block.

The application of that platforms saves  
on scaffolding costs or breakdown times.

To date more than 14.000 All Purpose  
Platforms are in use all over the world, a  
clear evidence for their reliability, safety,  
economical viability and advanced  
engineering.

包括手動操作緊急下降  
閘在內的所有控制元件  
均集成在液壓單體中。

本作業平台平台的使用節  
省鷹架費用或故障時間

迄今為止, 已有超過  
14000個作業平台在世界  
各地得到使用, 為可靠  
性, 安全性, 經濟可行  
性和先進工程提供了明  
確的證據



Member of F.E.M. (Germany)



## Lift KBE 5 / KB 5

### Mobility and safe working on appropriate height

在適當的高度流動性和安全工作

- Working height till abt. 5 m
- **KBE 5** → Electrically self-propelled type
- **KB 5** → Manually pushable type
- Easy access from floor
- Full stability without stabilisers
- Quick readiness for use
- Operation independant from mains power supply by maintenance-free gel-type batteries (KBE5), by low-maintenance block batteries (KB5)
- Joy stick stepless travel control from basket (KBE5)
- Push button control for lifting / lowering
- Large size tray located at basket
- Electro-hydraulic lifting
- Warning colour RAL 3000
- Incl. built-in battery charger
- 工作高度直到約 5米
- KBE 5 電動自走式
- KB 5 手動可推式
- 方便從地板進出
- 不用穩定器,完全穩定
- 快速準備使用
- 藉着免維護凝膠電池 (KBE5) 操作獨立於主電源供電, 由低維護塊電池 (KB5) 從籃子 (KBE5)
- 搖桿無段走行控制
- 按鈕控制作為上升/下降
- 大尺寸托盤位於籃子
- 電油壓上升
- 警告顏色RAL 3000
- 含內置電池充電器



Type		KBE 5	KB 5
Capacity	kg	150	150
Platform height	m	3,0	3,0
Working height	m	5,0	5,0
Travel speeds	km/h	3/1	-
Size of basket	mm	600x850x1 100	600x850x1 100
Battery	Volt	24 V	24 V
Dead weight	kg	680	470

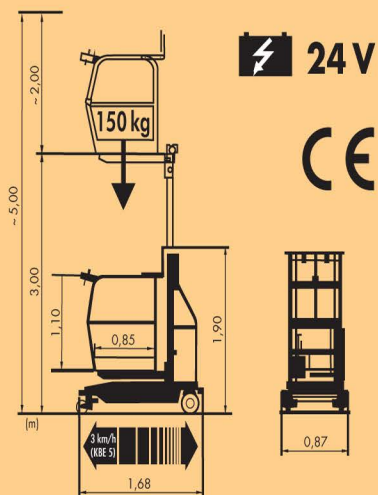

Whether for repairs or maintenance, for erection or storing into shelves - the Lift is always on appropriate height!

無論是維修還是維護，架設或存放在貨架上 - 本機總是在適當的高度！

