

**GIUNTI AD INNESTO RAPIDO E PISTOLE AD ARIA**

*AUTOMATIC QUICK COUPLINGS AND BLOW GUNS*

*SCHNELLVERSCHLUSS-KUPPLUNGEN UND BLASPISTOLEN*

*COUPLEURS AUTOMATIQUES ET SOUFFLETTES*

*ENCHUFES RÁPIDOS Y PISTOLAS DE AIRE*

*CONEXÕES DE ENGATE RÁPIDO E PISTOLAS DE AR*



**Serie Quick Couplings**

**Prese ad Innesto Rapido** - Quick Couplings - Schnellverschluss Kupplungen  
 Coupleurs Automatiques - Enchufes Rápidos - Conexões de Engate Rápido



**Prese di Sicurezza ad Innesto Rapido** - Safety Quick Couplings - Kupplungen Sicherheit - Coupleurs de Sécurité  
 Enchufes de Seguridad - Conexões de Segurança



**Giunti ad Innesto Rapido per Raffreddamento Stampi** - Quick Couplings for Molding Cooling - Schnellkupplungen Für Spritzgussanwendungen  
 Coupleurs pour Moulés D'injection - Enchufes Rápidos para Refrigeración de Moldes - Conexões de Engate Rápido para Resfriamento de Moldes



**Prese ad Innesto Rapido in ACCIAIO INOSSIDABILE** - STAINLESS STEEL Quick Couplings - Schnellverschluss Kupplungen in EDELSTAHL  
 Coupleurs Automatiques en ACIER INOXYDABLE - Enchufes Rápidos en ACERO INOXIDABLE - Conexões de Engate Rápido em AÇO INOXIDÁVEL



PLUG PROFILE 1:1	STANDARD	SERIE PLUG	STANDARD COUPLINGS	MULTI COUPLINGS	SERIE SAFETY	SERIE INOX	
	DN 5	MIGNON	210	110			
	DN 5	MIGNON DOUBLE SHUT OFF	280	180			
	DN 2.5	UNI-ISO 6150-A6	200	100			
	DN 5.5	UNI-ISO 6150-B12 INDUSTRIAL 1/4	220	120	190	620	
	DN 9	UNI-ISO 6150-B15 INDUSTRIAL 3/8	230	130	720		
	DN 12	UNI-ISO 6150-B17 INDUSTRIAL 1/2	810	710			
	DN 5.5	UNI-ISO 6150-C10	240	140			
	DN 7.5 - 7.8	EUROPEAN	260 63260	160	190	660	63190
	DN 10	EUROPEAN DN 10	820	720			
	DN 5.5	SWISS	270	170	190	670	
	DN 7.5	JAPANESE	500	400			
	DN 5	ITALIAN	250	120	190	650	
	DN 2.7	MINI	800	700			
	DN 8	FRENCH	510	410			
	DN 12	FRENCH	520	420			
	DN 6	INTERNATIONAL	530	430			
	DN 9	INTERNATIONAL	540	440			
	DN 6	EUROPEAN	560	460			
	DN 9	EUROPEAN	570	470			

ARIA - AIR - LUFT - AIR - AIRE - AR

ACQUA - WATER - WASSER - EAU - AGUA - ÁGUA  
 OLIO - OIL - ÖL - HUILE - ACEITE - ÓLEO

INTERCAMBIABILITÀ - INTERCHANGE - AUSTAUSCHBARKEIT - INTERCHANGEABILITÉ - INTERCAMBIABILIDAD - INTERCAMBIABILIDADE

RECTUS/LEGRIS PARKER 21/90	CAMOZZI 5050 - 5150	CEJN 220		FESTO KD - KS 3	
RECTUS/PARKER 21/90	CAMOZZI 5050 - 5150	CEJN 200			
				FESTO KD - KS 2	
RECTUS/LEGRIS 23/24 PARKER 20/30 - 1/4 TEMA 1400	HANSEN 3000	CEJN 310	INDUSTRIAL 1/4	GROMELLE 600	US - MIL SPEC C-4109
RECTUS/LEGRIS 30 PARKER 30 - 3/8	HANSEN 4000	CEJN 430	INDUSTRIAL 3/8	GROMELLE 900	US - MIL SPEC C-4109
RECTUS 37	HANSEN 5000	CEJN 550		GROMELLE 1300	US - MIL SPEC C-4109
RECTUS/LEGRIS 18					
RECTUS/LEGRIS 25/26/1600/1625 TEMA 1600	CAMOZZI 5080 - 5180	CEJN 320		FESTO KD - KS 6 KD - KS 4	
RECTUS/LEGRIS 27		CEJN 410			
RECTUS/LEGRIS 14/22 PARKER 50	HANSEN 210	CEJN 300		ARO 210	
RECTUS/LEGRIS 13	SMC KK130	CEJN 315	NITTO KOHKI 200		
RECTUS/LEGRIS PARKER 20/91				FESTO KD - KS 2	
RECTUS 608					
RECTUS 612					
RECTUS 86	DME 1/4				
RECTUS 87	DME 3/8				
RECTUS 10	HASCO Z80/811HT/9 [Øe 9]	CEJN 220 - 221 - 225			
RECTUS 11	HASCO Z80/811HT/13 [Øe 13.5]				

La gamma dei giunti ad innesto rapidi Aignep permette una risposta adeguata ai molteplici bisogni dei nostri clienti. Le differenti applicazioni, le prestazioni e l'affidabilità, sono i vantaggi dati dall'insieme di questa importantissima gamma.

A semplice o doppia intercettazione in ottone nichelato, in acciaio inox, conformi alle principali norme di riferimento possono essere utilizzati per veicolare molteplici fluidi.

A completamento pistole di soffiaggio.

## Principali vantaggi

- Passaggi da DN 2,5 a 12 mm
- Profili normalizzati
- Gamme Multipresa
- Montaggio con una sola mano
- Leggerezza ed ingombro ridotto
- Versioni di sicurezza
- Raffreddamento stampi normalizzati
- Silicon Free

## Applicazioni

- Impianti Aria Compressa e Strumenti
- Automazione Pneumatica e Fluidica
- Food & Beverage
- Life & Sciences
- Raffreddamento stampi
- Gas inerti, versioni per vuoto

*Aignep range of quick couplings is able to satisfy multiple needs of our customers.*

*Wide variety of models: single & double shut-off, multisocket, safety.*

*The most popular profiles and nominal diameters available in nickel-plated brass and stainless steel.*

*For compressed air and for moulding injection cooling system.*

*To complete the line a wide range of air blow guns.*

## Main advantages

- DN 2,5 - 12 mm
- Standard profiles
- Multisocket
- Single handed operation
- Light and compact
- Safety version
- Moulding couplers
- Silicon Free

## Applications

- Compressed Air & Tools
- Pneumatic & Fluidtechnology
- Food & Beverage
- Life & Sciences
- Cooling System
- Inert Gases, Vacuum

*Die Schnellverschlusskupplungs-Serie von Aignep antwortet auf die vielfältigen Bedürfnisse unserer Kunden. Zahlreiche verschiedene Modelle: Einzel- und Doppelabsperrung, Mehrfachstecker, Sicherheitskupplungen.*

*Die beliebtesten Profile und Nennweiten sind aus vernickeltem Messing und Edelstahl verfügbar.*

*Für Druckluft und für Spritzguss-Kühlsysteme zu formen. Zur Vervollständigung der Serie eine große Auswahl an Blaspistolen.*

## Hauptvorteile

- DN 2,5 – 12 mm
- Standard Profile
- Mehrfachstecker
- Einhändige Bedienung
- Leicht und kompakt
- Sicherheits Versionen
- Spritzwerkzeug-Kühlung
- Silikonfrei

## Anwendungen

- Druckluft & Werkzeuge
- Pneumatik und Fluidtechnik
- Lebensmittel & Getränke
- Life Science
- Kühlsysteme
- Inertgase, Vakuum

FR

Les coupleurs rapides Aignep répondent à de nombreuses utilisations. Grande variété de modèles en version simple et double obturation, multiprise, de sécurité. Les profils et les diamètres nominaux les plus courants sont disponibles en laiton nickelé et acier inoxydable 316L.

Pour air comprimé et tous fluides industriels ainsi qu'une gamme dédiée pour le refroidissement des moules dans l'injection plastique. Une large gamme de soufflettes vient compléter notre offre.

#### Principaux avantages

- DN 2,5 - 12 mm
- Profils standards
- Multisocket
- Opération d'une seule main
- Léger et compact
- Version de sécurité
- Coupleurs pour moule
- Sans silicone

#### Applications

- Air comprimé
- Outillage pneumatique
- Agro alimentaire
- Sciences de la vie
- Système de refroidissement
- Gaz neutres, vide

ES

La gama de enchufes rápidos Aignep permite una respuesta adecuada a las múltiples necesidades de nuestros clientes. Las diferentes aplicaciones, las prestaciones y la fiabilidad, son las ventajas que ofrece esta importantísima gama.

A simple y doble obturación en latón niquelado, acero inox, conforme a las principales normas de referencia pueden ser utilizados para vehicular múltiples fluidos. Completan esta gama las pistolas de soplado.

#### Principales ventajas

- Pasos de DN 2,5 a 12 mm
- Perfiles normalizados
- Gama Multipresa
- Montaje con una sola mano
- Ligereza y reducidas dimensiones
- Versión de seguridad
- Refrigeración de moldes normalizados
- Libres de silicona

#### Aplicaciones

- Instalaciones de aire comprimido y herramientas
- Automatización neumática y fluidica
- Alimentos y bebidas
- Life & Science
- Refrigeración de moldes
- Gases inertes, versiones para vacío

PT

A linha de engates rápidos Aignep pode satisfazer as diferentes necessidades dos consumidores. Ampla gama: fechamento simples ou duplo, multisocket, segurança.

Os itens mais populares e diâmetros nominais estão disponíveis em latão niquelado ou aço inox.

A linha é adequada para ar comprimido e resfriamento de moldagem.

Completam a linha as pistolas de ar.

#### Principais Vantagens

- DN 2,5 - 12 mm
- Perfil-padrão
- Multisocket
- Instalação fácil - com uma só mão
- Leve e compacta
- Engate de Segurança
- Engates Resfriamento
- Livre de silicone

#### Aplicação

- Ar Comprimido & Ferramentas
- Pneumática & Tecnologia de Fluidos
- Alimentos e bebidas
- Life & Sciences
- Sistemas de Resfriamento
- Gases Inertes, Vácuo

MULTIPRESA IN ACCIAIO INOX  
 STAINLESS STEEL MULTISOCKET  
 KUPPLUNGEN AUS EDELSTAHL  
 COUPLEURS AUTOMATIQUES EN ACIER INOXYDABLE  
 MULTIPRESA EN ACERO INOX  
 CONEXÃO MULTISOCKET EM AÇO INOX

AISI 316L



**CARATTERISTICHE TECNICHE**  
 TECHNICAL CHARACTERISTICS  
 TECHNISCHE ANGABEN  
 CARACTÉRISTIQUES TECHNIQUES  
 CARACTERÍSTICAS TÉCNICAS  
 CARACTERÍSTICAS TÉCNICAS



**Norma di Riferimento**

- Reference standard
- Entspricht der Norm
- Norme de référence
- Normativa de referencia
- Norma de referência

1907/2006 REACH ✓	2011/65/CE RoHS ✓
PED 2014/68/UE	SILICON FREE

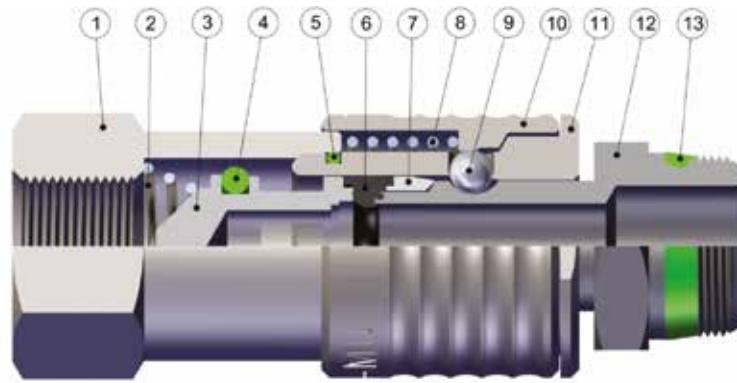

**Materiali e Componenti**

IT

- 1 Attacco terminale in acciaio INOX AISI 316L
- 2 Molla otturatore in acciaio INOX AISI 302
- 3 Otturatore in acciaio INOX AISI 316L
- 4 Guarnizione O-Ring Otturatore in FKM alimentare
- 5 Guarnizione O-Ring corpo in FKM alimentare
- 6 Guarnizione innesto in FKM alimentare
- 7 Anello guida innesto in acciaio INOX AISI 316L
- 8 Molla ghiera in acciaio INOX AISI 302
- 9 Sfera in acciaio INOX AISI 420
- 10 Ghiera in acciaio INOX AISI 316L
- 11 Corpo in acciaio INOX AISI 316L
- 12 Innesto in acciaio INOX AISI 316L
- 13 Guarnizione filetto in FKM alimentare

**Component Parts and Materials**

GB

- 1 AISI 316L Steel coupling back part
- 2 AISI 302 Steel shutter thrust spring
- 3 AISI 316L Steel shutter
- 4 Food FKM shutter O-Ring seal
- 5 Food FKM body O-Ring seal
- 6 Food FKM plug seal
- 7 AISI 316L Steel guide ring coupling
- 8 AISI 302 Steel ring nut spring
- 9 AISI 420 Steel ball
- 10 AISI 316L Steel sleeve
- 11 AISI 316L Steel body
- 12 AISI 316L Steel plug outline
- 13 Food FKM thread packing

**Komponenten und Materialien**

DE

- 1 Einschraubkörper edelstahl AISI 316L
- 2 Verschlussfeder edelstahl AISI 302
- 3 Verschluss edelstahl AISI 316L
- 4 Verschluss O-Ring FKM Lebensmittel
- 5 Körper O-Ring FKM Lebensmittel
- 6 Stecker O-Ring FKM Lebensmittel
- 7 Stecker führungsring edelstahl AISI 316L
- 8 Entriegelungsfeder edelstahl AISI 302
- 9 Kugel edelstahl AISI 420
- 10 Entriegelungshülse edelstahl AISI 316L
- 11 Körper edelstahl AISI 316L
- 12 Stecker edelstahl AISI 316L
- 13 Gewindedichtung FKM Lebensmittel

**Matériaux et Composants**

FR

- 1 Corps: AISI 316L
- 2 Ressort de clapet: AISI 302
- 3 Clapet: AISI 316L
- 4 Joint torrique: FKM conforme alimentaire
- 5 Joint torrique: FKM conforme alimentaire
- 6 Joint: FKM conforme alimentaire
- 7 Bague de guidage: AISI 316L
- 8 Ressort de bague: AISI 302
- 9 Bille: AISI 420
- 10 Bague: AISI 316L
- 11 Corps: AISI 316L
- 12 Embout: AISI 316L
- 13 Etanchéité: conforme alimentaire

**Materiales y Componentes**

ES

- 1 Terminal de conexión en acero INOX AISI 316L
- 2 Muelle obturador en acero INOX AISI 302
- 3 Obturador en acero INOX AISI 316L
- 4 Junta tórica Obturador en FKM alimentaria
- 5 Junta tórica cuerpo en FKM alimentaria
- 6 Junta adaptador en FKM alimentaria
- 7 Anillo guía adaptador en acero INOX AISI 316L
- 8 Muelle tuerca en acero INOX AISI 302
- 9 Esfera en acero INOX AISI 420
- 10 Tuerca en acero INOX AISI 316L
- 11 Cuerpo en acero INOX AISI 316L
- 12 Adaptador en acero INOX AISI 316L
- 13 Junta rosca en FKM alimentaria

**Materiais e Componentes**

PT

- 1 Engate terminal em aço INOX AISI 316L
- 2 Mola do obturador em aço INOX AISI 302
- 3 Obturador em aço INOX AISI 316L
- 4 Vedação O-Ring do Obturador em FKM alimentício
- 5 Vedação O-Ring do corpo em FKM alimentício
- 6 Vedação do plug em FKM alimentício
- 7 Anel guia do plug em aço INOX AISI 316L
- 8 Mola da porca em aço INOX AISI 302
- 9 Esfera em aço INOX AISI 420
- 10 Porca em aço INOX AISI 316L
- 11 Corpo em aço INOX AISI 316L
- 12 Plug em aço INOX AISI 316L
- 13 Vedção de rosca em FKM alimentício

**Pressione d'esercizio**
*Working Pressures*
*Betriebsdruck*
*Pression de service*
*Presión de Ejercicio*
*Pressão de Trabalho*
**0 bar** (0 MPa)

**16 bar** (1.6 MPa)

**Max pressione statica (no pulsazioni)**
*Maximum static pressure (no pulsations)*
*Maximaler statischer Betriebsdruck (ohne pulsations)*
*Pression statique maximale (sans pulsation)*
*Presión estática máxima (sin pulsaciones)*
*Pressão estática máxima (sem pulsações)*
**35 bar**

**Temperature**
*Temperatures*
*Temperatur*
*Températures*
*Temperaturas*
*Temperaturas*
**- 15 °C**
**+ 200 °C**

**Fluidi compatibili**
**Aria compressa**

Fluidi per Industria alimentare e chimica compatibili con i componenti.

**Fluids**
**Compressed air**

Fluid for food and chemical industry compatible with all components.

**Geeignete Medien**
**Druckluft**

Medien für die Lebensmittel- und chemische Industrie, die beständig mit den Komponenten der Verschraubungen sind.

**Fluides compatibles**
**Air comprimé**

Fluides alimentaires et chimiques compatibles avec les matériaux constituant les raccords.

**Fluidos compatibles**
**Aire comprimido**

Fluidos para industria alimentaria y química compatibles con los componentes del racor.

**Fluidos compatíveis**
**Ar comprimido**

Fluidos para Indústria alimentícia e química compatíveis com os componentes da conexão.

**Filettatura**
**IT**

 Gas cilindrica conforme ISO 228 Classe A.  
 Gas conica "UNIVERSAL SHORT".

**Threads**
**GB**

 Parallel gas in conformity with ISO 228 Class A.  
 "UNIVERSAL SHORT" Tapered thread.

**Gewindearten**
**DE**

 Zylindrisches Gewinde nach Norm ISO 228 Classe A.  
 Konisches Gewinde "UNIVERSAL SHORT".

**Filetages**
**FR**

 Filetage cylindrique conforme: ISO 228 Class A.  
 Filetage conique "UNIVERSAL SHORT".

**Roscas**
**ES**

 Gas cilíndrica conforme ISO 228 Clase A.  
 Gas cónica "UNIVERSAL SHORT".

**Roscas**
**PT**

 Gas paralela conforme ISO 228 Classe A.  
 Gas cónica "UNIVERSAL SHORT".



## 63190

### PRESA CON ATTACCO MASCHIO "UNIVERSAL SHORT"

MALE SOCKET "UNIVERSAL SHORT"

KUPPLUNG MIT AUSSENGEWINDE "UNIVERSAL SHORT"

CORPS MÂLE "UNIVERSAL SHORT"

ENCHUFE MACHO "UNIVERSAL SHORT"

SOQUETE COM ROSCA MACHO TIPO "UNIVERSAL SHORT"



Code	A	B	C	D	CH	Pack.
63190 00 002	1/4	7	50	24	21	2
63190 00 003	3/8	7.5	50.5	24	21	2
63190 00 004	1/2	9	52	24	21	2

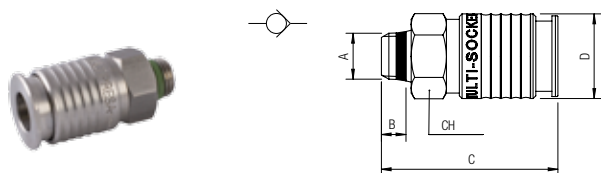

## 63192

### PRESA CON ATTACCO FEMMINA

FEMALE SOCKET

KUPPLUNG MIT INNENGEWINDE

CORPS FEMELLE

ENCHUFE HEMBRA

SOQUETE COM ROSCA FÊMEA



Code	A	B	C	D	CH	Pack.
63192 00 002	1/4	11	51.5	24	21	2
63192 00 003	3/8	11.5	52	24	21	2
63192 00 004	1/2	15	56.5	24	24	2

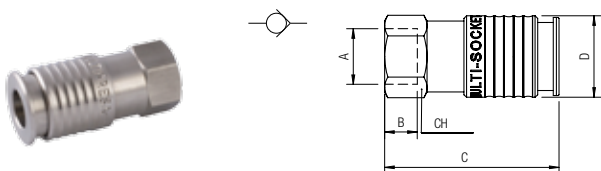

## 63260 DN 7.8

### INNESTO PROFILO EUROPEO CON ATTACCO MASCHIO "UNIVERSAL SHORT"

MALE PLUG EUROPEAN PROFILE "UNIVERSAL SHORT"

STECKER MIT AUSSENGEWINDE "UNIVERSAL SHORT" - EUROPEAN

EMBOUT MÂLE "UNIVERSAL SHORT" - PROFIL EUROPEEN

ADAPTADOR PERFIL EUROPEO MACHO "UNIVERSAL SHORT"

PLUG COM PERFIL EUROPEU E ROSCA MACHO TIPO "UNIVERSAL SHORT"



Code	A	B	C	D	CH	Pack.
63260 00 002	1/4	7	33.5	-	17	2
63260 00 003	3/8	7.5	34	-	19	2
63260 00 004	1/2	9	36	-	24	2

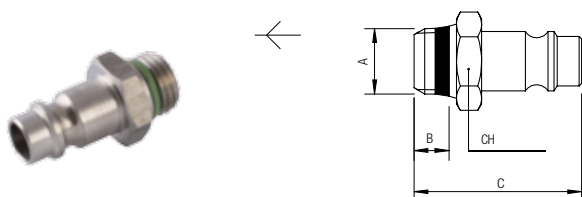

## 63262 DN 7.8

### INNESTO PROFILO EUROPEO CON ATTACCO FEMMINA

FEMALE PLUG EUROPEAN PROFILE

STECKER MIT INNENGEWINDE - EUROPEAN

EMBOUT FEMELLE - PROFIL EUROPEEN

ADAPTADOR PERFIL EUROPEO HEMBRA

PLUG COM PERFIL EUROPEU E ROSCA FÊMEA



Code	A	B	C	D	CH	Pack.
63262 00 44 03 00	1/4	11	33	-	17	2
63262 00 44 04 00	3/8	11.5	33.5	-	19	2
63262 00 44 05 00	1/2	15	37	-	24	2

