

TECHNICAL SPECIFICATION

Piston Size	ϕ 30.23mm*4	'PL' Dimension	33.75mm
Piston Area	14.4cm ² *2	Caliper Body	2 pieces
Piston Material	Aluminum Alloy	Caliper Material	Aluminum Alloy Forged
Disc Diameter	ϕ 320(MAX)mm		
Disc Thicknesses	3.5(MIN)~5(MAX)mm		
Weight(Less Pads)	0.72kg		
Hydraulic Threads	M10*1.25		
Mounting	Radial		
- centres	85mm		
- offset	27.5mm		
- hole ϕ	10.1mm		

PAD FAMILY(LEA6)

Pad Area=19.63cm²

Pad Depth=30mm

Pad Thickness - Sintered=8.3mm(plate thickness 3.6mm)

Pad Weight =0.28kg(2 pieces)

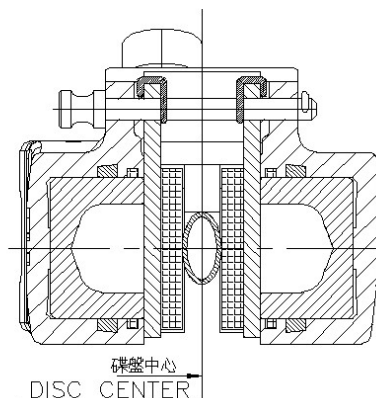
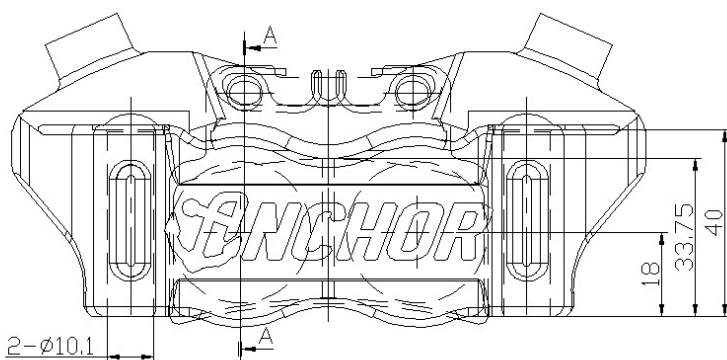
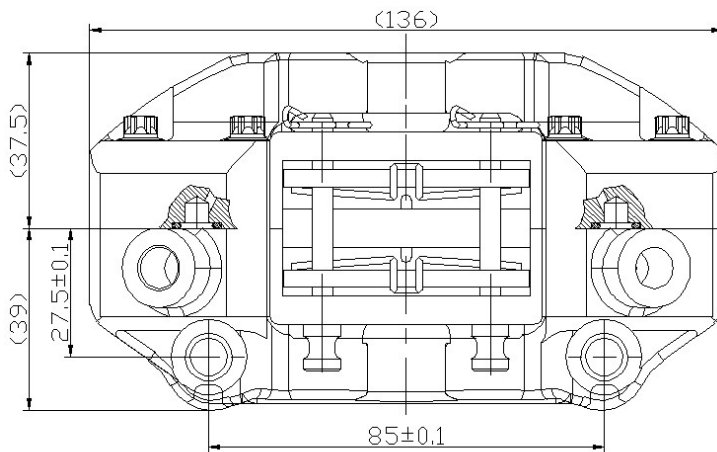
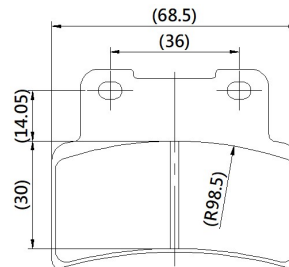

unit:mm

隼湧國際貿易股份有限公司

JOYOM INTERATIONAL TRADING CO.,LTD.