

TECHNICAL SPECIFICATION

Piston Size	ϕ 33.96mm*4	Length:20mm		
Piston Area	18.1cm ² *2		'PL' Dimension	28.7mm
Piston Material	Aluminum Alloy		Caliper Body	2 pieces
Disc Diameter	ϕ 320(MAX)mm		Caliper Material	Aluminum Alloy Forged
Disc Thicknesses	3.5(MIN)~5(MAX)mm			
Weight(Less Pads)	0.85kg			
Hydraulic Threads	M10*1.0			
Mounting	Radial			
- centres	108mm			
- offset	22.5mm			
- hole ϕ	10.1mm			

PAD FAMILY(PAD-ISI06)

Pad Area=20.6cm²

Pad Depth=30.2mm

Pad Thickness - Sintered=8.6mm(panel thickness 3.2mm)

Pad Weight =0.2kg(2 pieces)

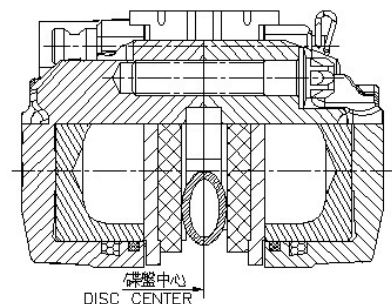
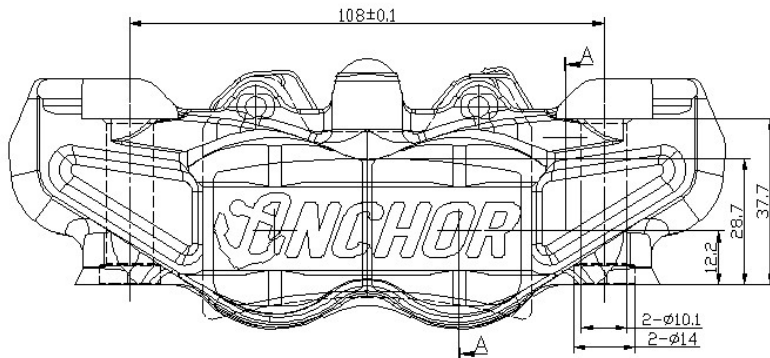
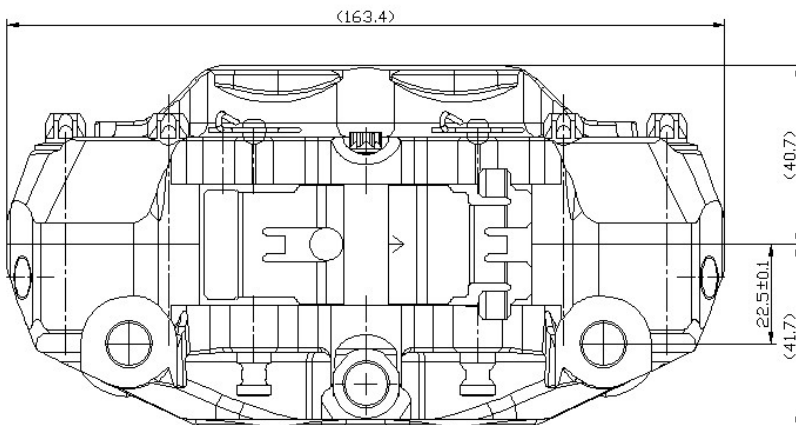
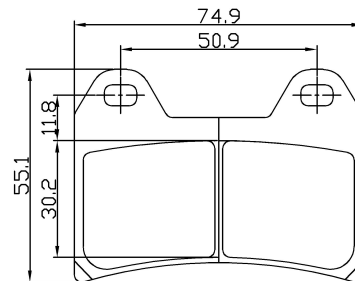

unit:mm

隼湧國際貿易股份有限公司

JOYOM INTERNATIONAL TRADING CO.,LTD.