

## ● 6FMP2

**TECHNICAL SPECIFICATION**

Piston Size	$\phi 30.23\text{mm} * 2 + \phi 32\text{mm} * 2 + \phi 32\text{mm} * 2$		
Piston Area	$23.26\text{cm}^2 * 2$	'PL' Dimension	46mm
Piston Material	Aluminum Alloy , SUS	Caliper Body	2pieces
Disc Diameter	$\phi B$	Caliper Material	Aluminum Alloy Forged
Disc Thicknesses	T:24mm(T22~T25mm)		
Weight(Less Pads)	1.85kg(One side)		
Hydraulic Threads	M10*1.0		
Mounting	Radial		
centres	160mm		
offset	26.5mm		
hole $\phi$	10.1mm		



**PAD FAMILY(HF4CMP1)**

 Pad Area=47.3cm<sup>2</sup>

Pad Depth=45mm

Pad Thickness=13.5mm(with shim, panel thicknes 5.5mm)

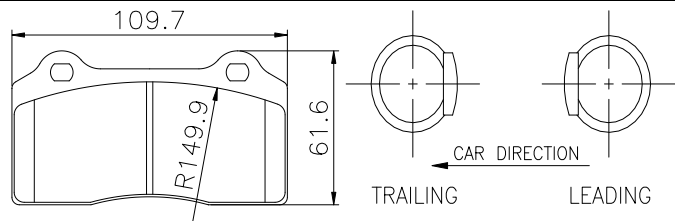
Pad Weight =0.68kg(2pieces)



NO	DISC $\phi B/T$	$\phi A$	$\phi B$	$\phi C$	$\phi D$	E
1	$\phi 282$ T24	320.1	282	243.28	198.51	93.5
2	$\phi 303$ T24	344.1	303	266.12	221.49	105.5

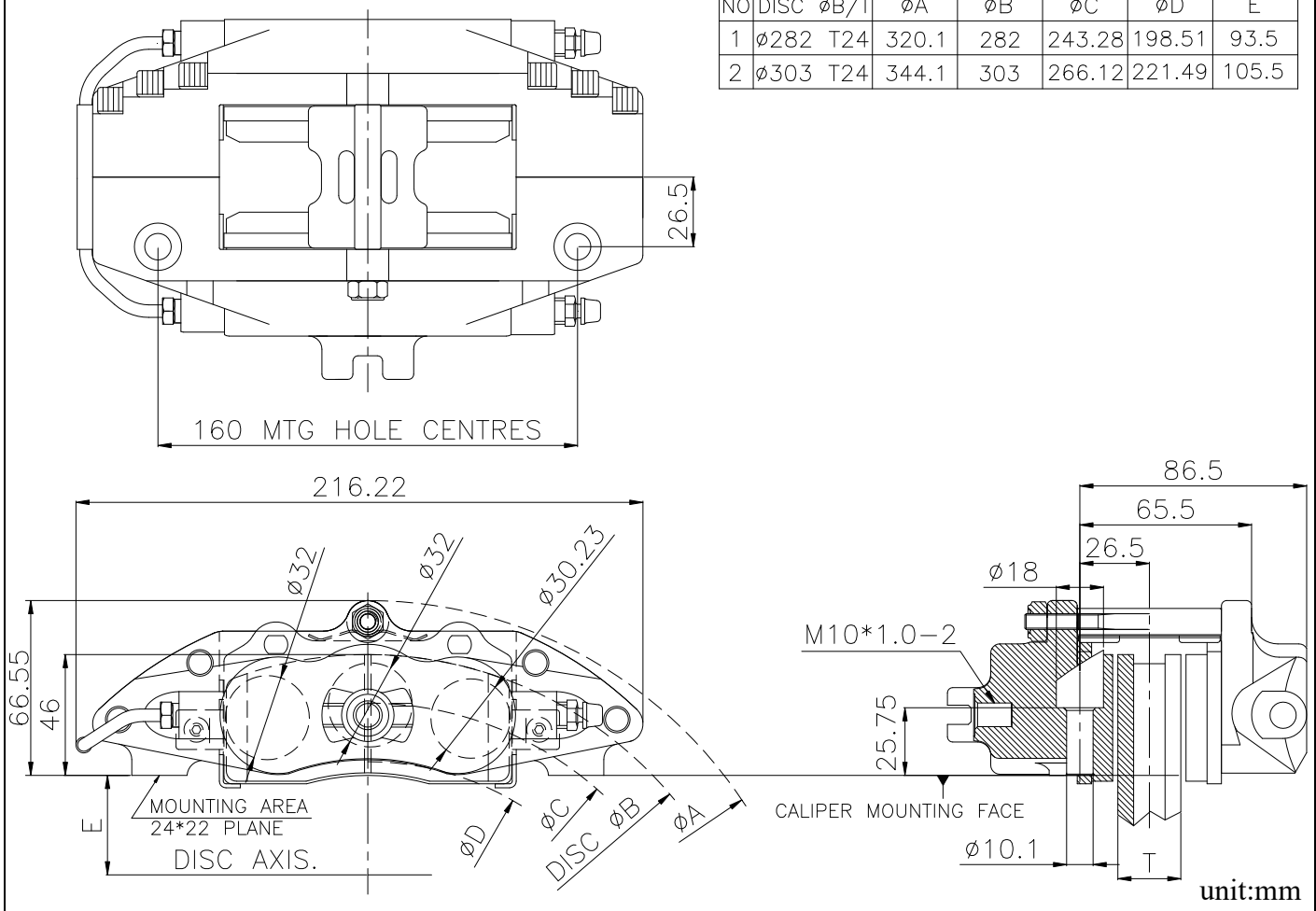

泓輔企業股份有限公司

Horng Fuu Industrial CO.,LTD.