

TECHNICAL SPECIFICATION

Piston Size	$\phi 30.23\text{mm} * 2 + \phi 33.96\text{mm} * 2$	
Piston Area	$16.2\text{cm}^2 * 2$	'PL' Dimension 80.4mm
Piston Material	Aluminum Alloy	Caliper Body 2 pieces
Disc Diameter	$\phi 226\text{mm}$	Caliper Material Aluminum Alloy CNC
Disc Thicknesses	3.5(MIN)~5(MAX)mm	
Weight(Less Pads)	0.69kg	
Hydraulic Threads	M10*1.25	
Mounting	Axial(Lug)	
- centres	60mm	
- offset	14.1mm	
- threads	M8*1.25	

PAD FAMILY(59-110)

Pad Area=21.56cm²
 Pad Depth=33.8mm
 Pad Thickness - Organic=8.5mm(plate thickness 3mm)
 - Sintered=8mm(plate thickness 3.2mm)
 Pad Weight =0.24kg(2 pieces)

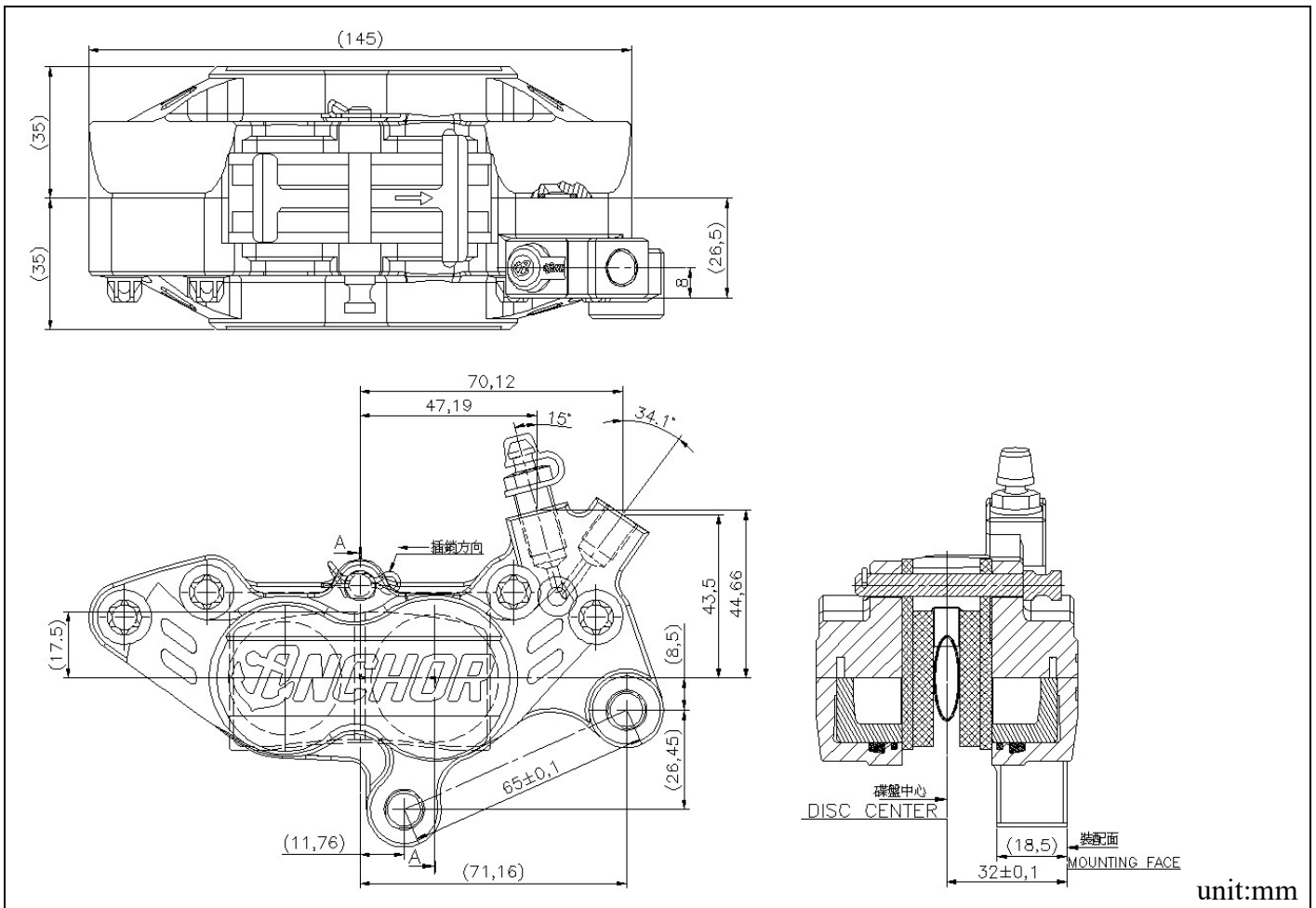
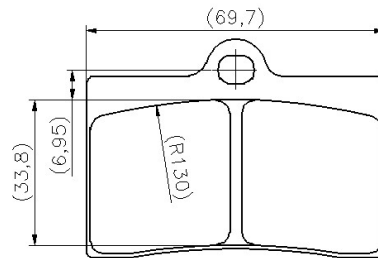

隼湧國際貿易股份有限公司

JOYOM INTERNATIONAL TRADING CO.,LTD.