

TECHNICAL SPECIFICATION

Piston Size	$\phi 32\text{mm} \times 4$	'PL' Dimension	34mm
Piston Area	$16.1\text{cm}^2 \times 2$	Caliper Body	2 pieces
Piston Material	Aluminum Alloy	Caliper Material	Aluminum Alloy Forged
Disc Diameter	$\phi 320(\text{MAX})\text{mm}$		
Disc Thicknesses	3.5(MIN)~5(MAX)mm		
Weight(Less Pads)	0.8kg		
Hydraulic Threads	M10*1.0		
Mounting	Radial		
- centres	108mm		
- offset	22.5mm		
- hole ϕ	10.1mm		

PAD FAMILY(PAD-ISI-A01、PAD-ISI-A02)

Pad Area=12.9cm²

Pad Depth=27mm

Pad Thickness - Sintered=8.4mm(with shim panel thickness 4.3mm)

Pad Weight =0.2kg(2 pieces)

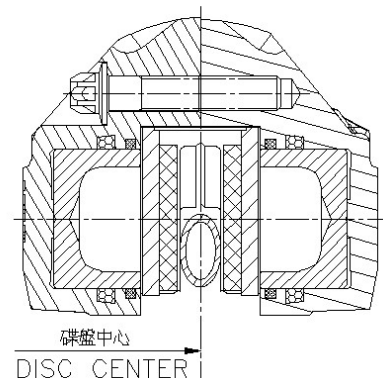
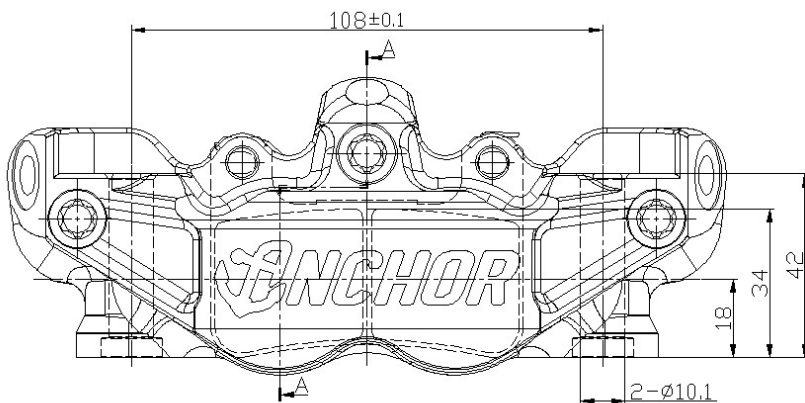
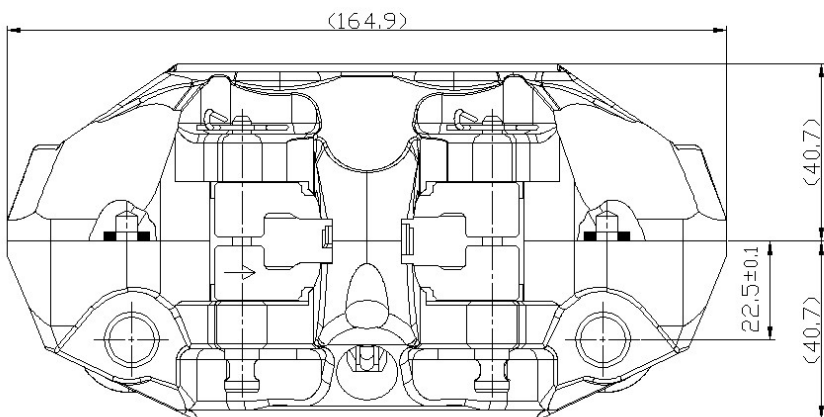
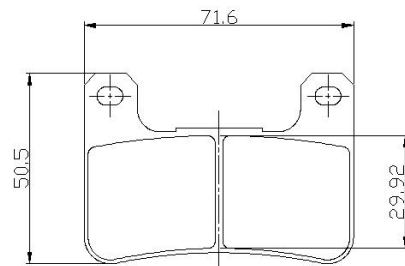

unit:mm

隼湧國際貿易股份有限公司

JOYOM INTERATIONAL TRADING CO.,LTD.