

● ANB9



RADIAL FORGED MASTER CYLINDER
ANB9 輻射鍛造總泵

TECHNICAL SPECIFICATION

Piston Size	9/16" (ø14.28mm), 5/8" (ø15.87mm), 11/16" (ø17.46mm), 3/4" (ø19.05mm)
Piston Material	Aluminum Alloy
Distance Center to Center	20mm
Construction Material	Aluminum Alloy Forged
Finishing	Hard Anodizing
Weight	0.36kg
Hydraulic Threads	M10*1.25
Brake Fluid	DOT4
Configuration	Right/Left Hand

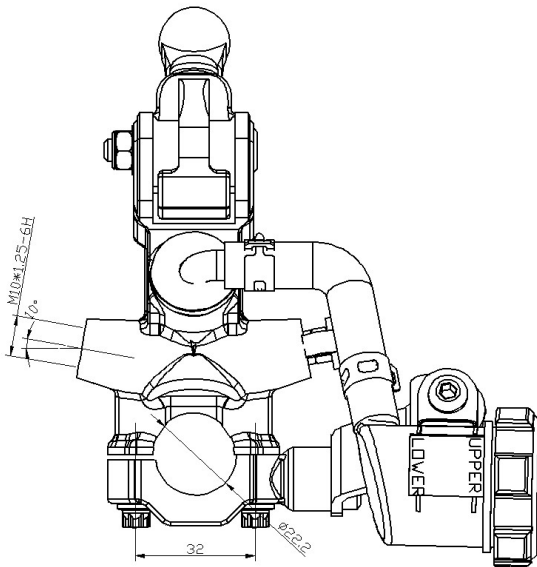
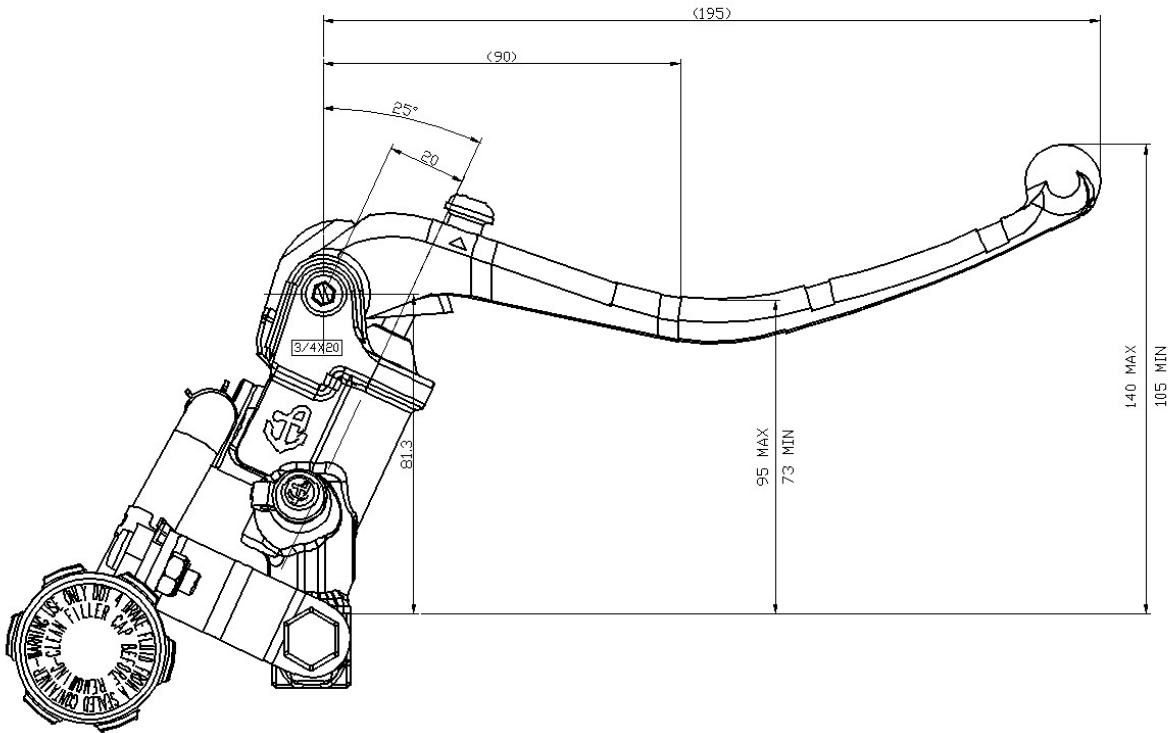

unit:mm



泓輔企業股份有限公司
Horng Fuu Industrial CO.,LTD.

<http://www.anchor-brake.com.tw/>

E-mail: sa2@horngfuu.com.tw TEL: +886-3-371-0789 FAX: +886-3-371-0777